

REVISIONS					
DATE	REV.	DESCRIPTION	AUTHOR	DRAWN BY	APPROVED

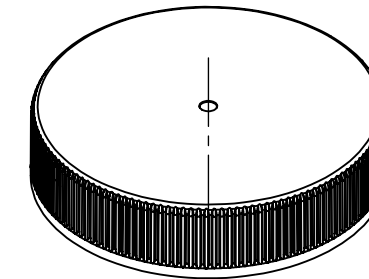

ISOMETRIC VIEW  
ACTUAL SIZE

SECTION A-A

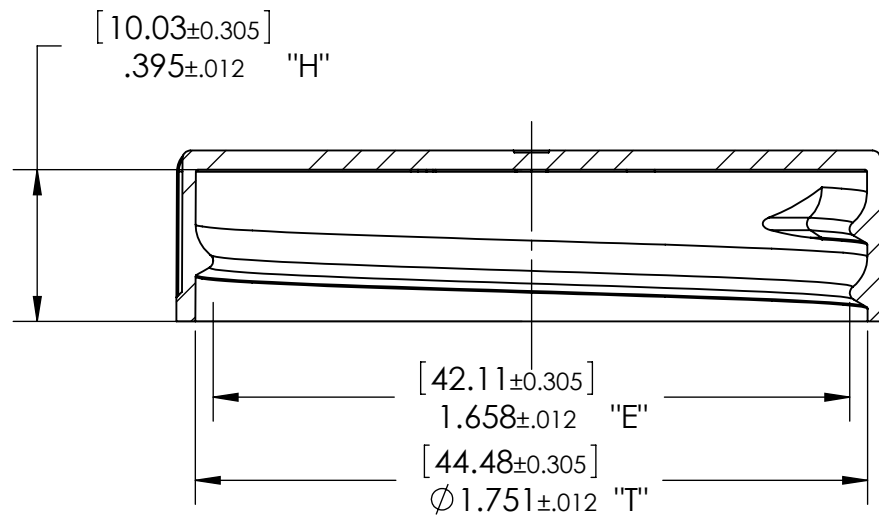
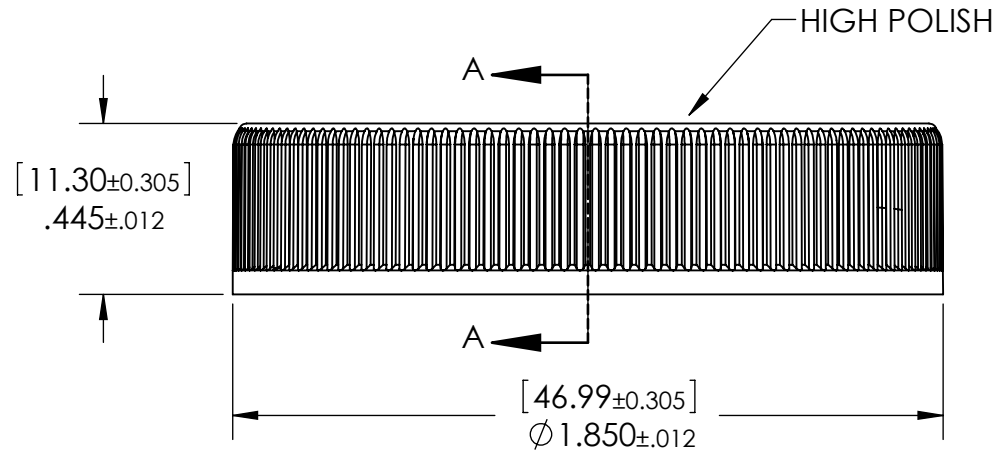
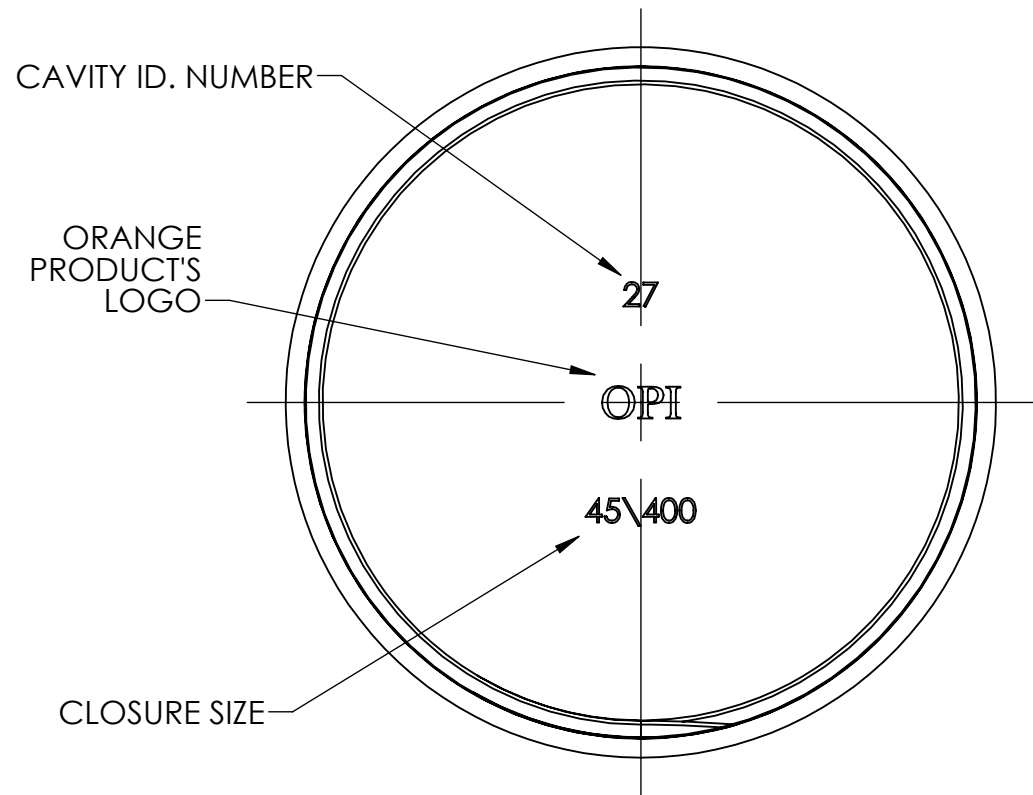

**THREAD SPECIFICATIONS:**

6 THREADS PER INCH, .1667" PITCH  
FULL DEPTH THREAD AT 380°



**ORANGE PRODUCTS, Inc.**

1929 Vultee St,  
Allentown, PA, 18103  
[www.orangeproducts.com](http://www.orangeproducts.com)

**Part name:**  
45 mm CT CLOSURE RIBBED

**Project name:**  
45 mm CT CLOSURE

**Material:**  
POLYPROPYLENE

**Weight:**  
3.6 ±.3 gr

**Designed by:**  
S. Loukov

**Approved by:**  
Steve DeSmedt

**CONFIDENTIAL PROPERTY**

The reproduction, use, or disclosure, in whole or in part, of the design, or details contained herein is prohibited without prior written consent of Orange Products, Inc.

All dimensions in inches. General tolerances according to DIN 16901.



<input checked="" type="checkbox"/> <b>INF</b> Issued for Information	<input type="checkbox"/> <b>IFA</b> Issued for Approval	<input type="checkbox"/> <b>IFC</b> Issued for Construction	<input type="checkbox"/> <b>IFP</b> Issued for Production
--	--	--	--

Scale	Size	Drawing number	Rev.	Date
2:1	B	16351PD-45mm	N/A	2/24/2017



# FoilSeal™ Technical Data Sheet

## .020" PS Foam FS 5-8

Revision: FS58-05062020

<b>Product</b>	.020" PS Foam FS 5-8																	
<b>Scope</b>	One piece foam backed heat induction foil inner seal which will provide a tamper-evident bond to PE, PS, PET, PVC, PP and treated glass containers. It is recommended for use with dry and semi-liquid products not containing essential oils. FS 5-8 is an alternative to FS 5-4.																	
<b>Composition</b>	<table border="1"> <thead> <tr> <th>Material</th> <th>Standard</th> <th>Metric</th> </tr> </thead> <tbody> <tr> <td>Backing</td> <td>.020"</td> <td>.508 mm</td> </tr> <tr> <td>Paper</td> <td>.002"</td> <td>.0508 mm</td> </tr> <tr> <td>Foil</td> <td>.0003"</td> <td>.0076 mm</td> </tr> <tr> <td>Heat Seal</td> <td>.0015"</td> <td>.0381 mm</td> </tr> </tbody> </table>	Material	Standard	Metric	Backing	.020"	.508 mm	Paper	.002"	.0508 mm	Foil	.0003"	.0076 mm	Heat Seal	.0015"	.0381 mm		
Material	Standard	Metric																
Backing	.020"	.508 mm																
Paper	.002"	.0508 mm																
Foil	.0003"	.0076 mm																
Heat Seal	.0015"	.0381 mm																
	Adhesive or resin bonding layers not shown.																	
<b>FDA Status:</b> 21 CFR 177.1210	<b>Recommended Storage and Handling:</b> Refer to Website.																	
<b>Drug Master File (DMF):</b> #4544	<b>EU / EP Reg.:</b> Compliant with Reg. EC/10/2011, Reg. EC/1935/2004 and Reg. EC/2023/2006, as amended, for use with dry, non-fatty, and non-alcoholic food products only. If used incorrectly, the liner may have an effect on the organoleptic properties of the product under EC/1935/2004 Article 3 and EC/2023/2006 Article 3a																	
<b>GTR Oxygen:</b> Essentially Zero	<b>MVTR:</b> Essentially Zero																	
<b>Sealing to glass containers:</b> Selig can not guarantee the performance or seal integrity of this materials when applied to any glass (treated or untreated) container. We suggest you contact your glass supplier for recommendations on glass treatments that may or may not improve performance or seal integrity.																		
<b>Print Location (if any):</b> Heat Seal Layer and/or Backing																		

Selig materials are compliant with current USFDA Food allergen Guidelines.

Selig materials are compliant with California Proposition 65 labeling requirements.

Selig materials are compliant with limitation of heavy metals in packaging per CONEG & EU 94/62/EC, article 11.

Recommended for use with dry food products. Is not suitable for use with fatty or alcoholic food types per ECC Reg. № 10/2011. Determining specific organoleptic compatibility per Article 3a of ECC Reg. № 2023/2006 is the responsibility of the food packager.

MSDS's are not required as Selig is not a chemical manufacturer or distributor and our products are 'articles' intended for food packaging per 29 CFR 1910.1200 (HazCom).

The information contained within this product data bulletin is to be used as a general guide in determining which structures are offered for sealing to specific container materials. All of the information which we provide is reliable to the best of our knowledge, but the accuracy thereof is not guaranteed. We suggest that consumers determine suitability for their own application.