

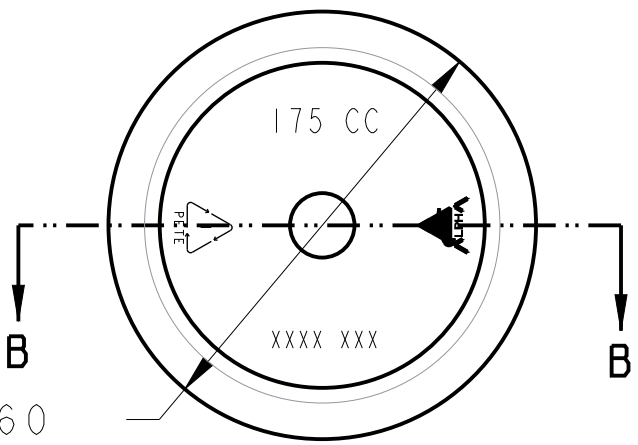

R.188
[4,78]

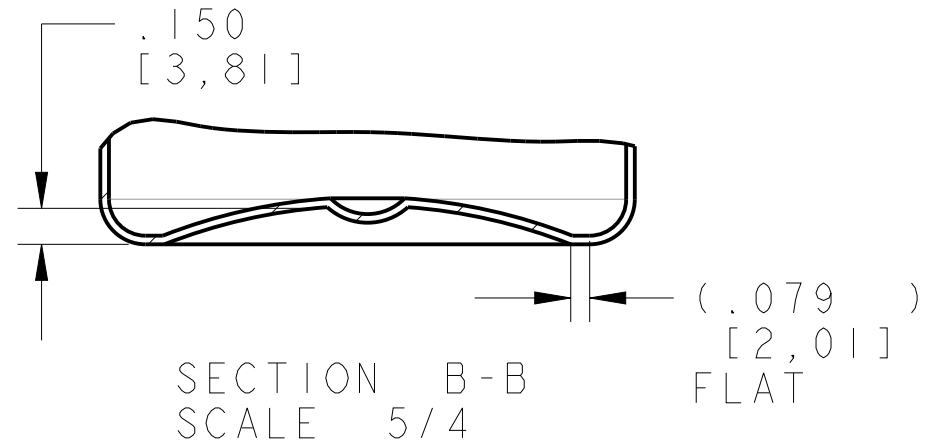

Neck Finish:		DISCLAIMER: Alpha Packaging assumes no responsibility for form, fit and function of closures, accessories, and/or shelf life and compatability of intended contents with this bottle.					
©Alpha Packaging, Inc.	Min Thk	Color	Weight	Std. Pack	Revisions		
All measurements are in inches	.012[.30]	All Colors	24 Gms±3	420,Stack	A	Add Metric 5/3/10.sct	
	.012[.30]	All Colors Heavy Gram	26 Gms±3	420,Stack	B	Add 26g.9/4/13.sct	
					C	REVISED BASE ENGRAVING	
						12/11/19 ZAJ	
Neck Dimensions:				Tolerance: Where not shown		 Alpha Packaging, Inc. (314) 427-4300-(800) 421-4772 Scale: 1/1 Drawn By: SCT Date: 087-02-09	
T = 1.464±.042 E = 1.370±.012 H = .403±.015 I = .987 MIN S = .046±.015				Decimal ±0.050 Angular ±1°			
Overflow Capacity: 191 ml ± 6				Material: PET		175cc, STRAIGHT SIDED, PET, WIDE STYLE, 38-400 CT 175S38PET	
				Approved By: S J		DwgRev: C Drawing NO: 175PMIWS38L400	

Ø2.227±.060
[56,57±1,52]

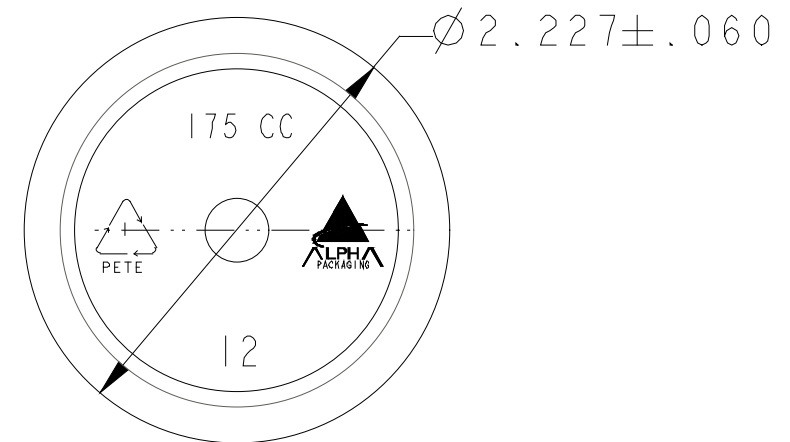
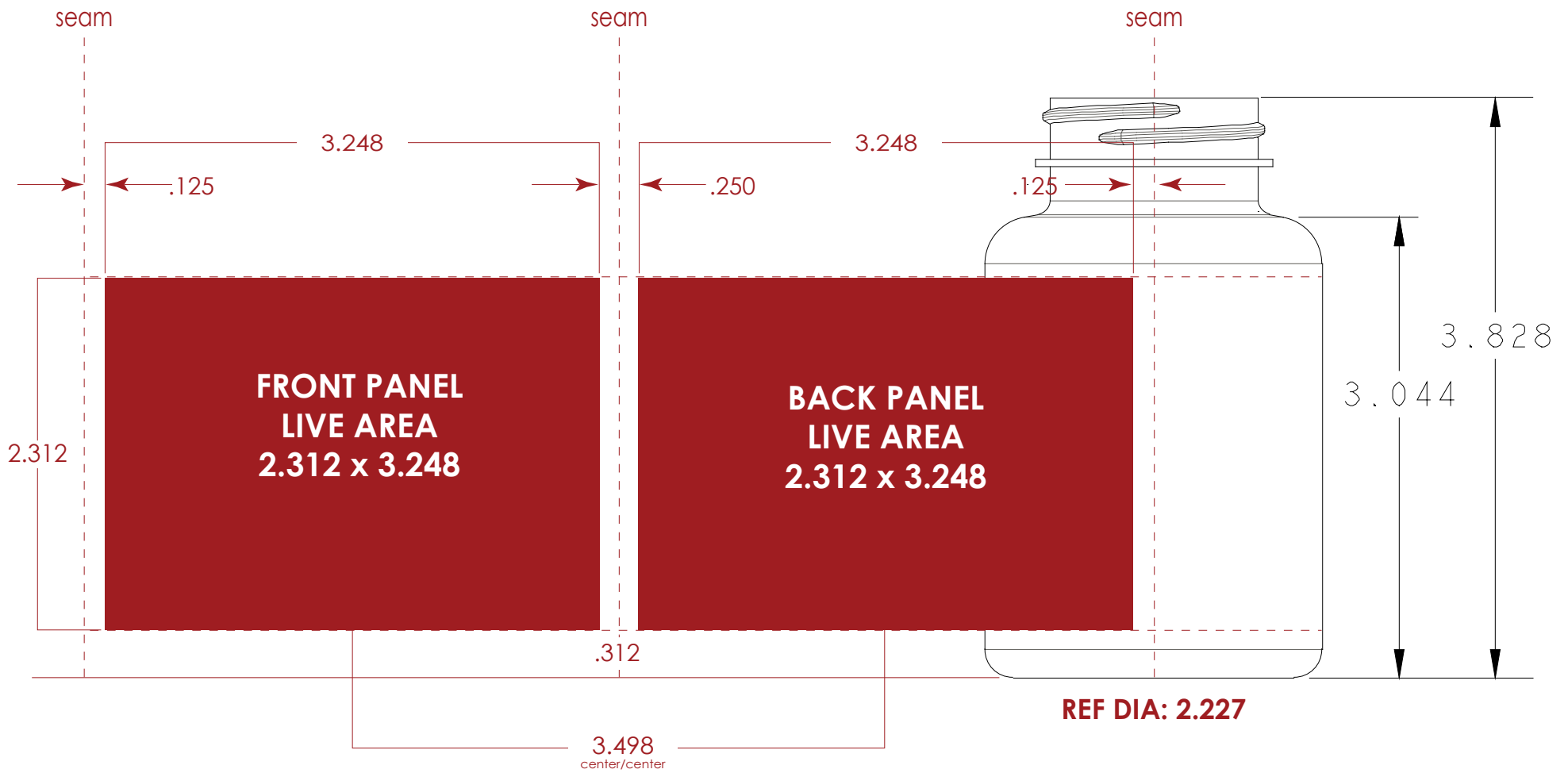

Technigraph
CORPORATION

SCALE 1-1 Actual Size

APPROVED: **DATE: 03/12/09**

The ART & TECHNOLOGY of PACKAGE DECORATION
PHONE 907-454-3830 FAX 907-454-6470

TECHNIGRAPH STOCK NUMBER: Estimated decorating template

This preliminary decorating template is for the bottle defined per
 • Alpha drawing number 175PMIWS38L400 •
 For specific bottle details please refer to the latest
 engineer drawing/revision for this container.

ALPHA
PACKAGING

ALPHA Packaging, Inc
 (314) 427-4300 - (800) 421-4772

**175cc, STRAIGHT SIDED, PET,
 WIDE STYLE, 38-400 CT**

Drawing NO:
 175PMIWS38L400