

1 2 3 4 5 6 7 8

A
B
C
D
E
F

A
B
C
D
E
F

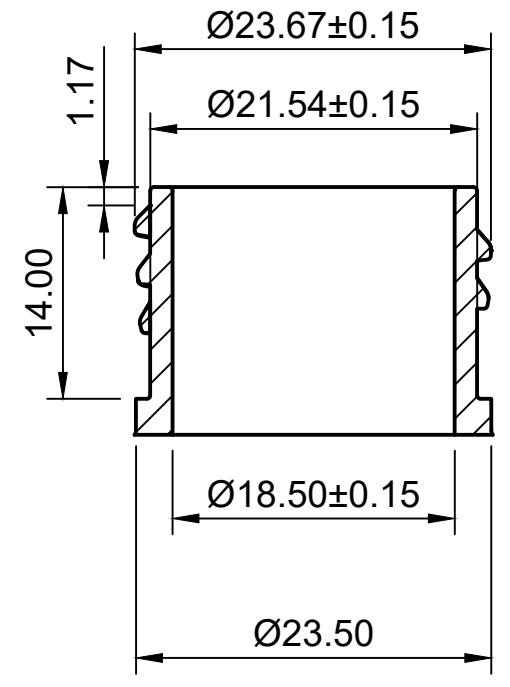
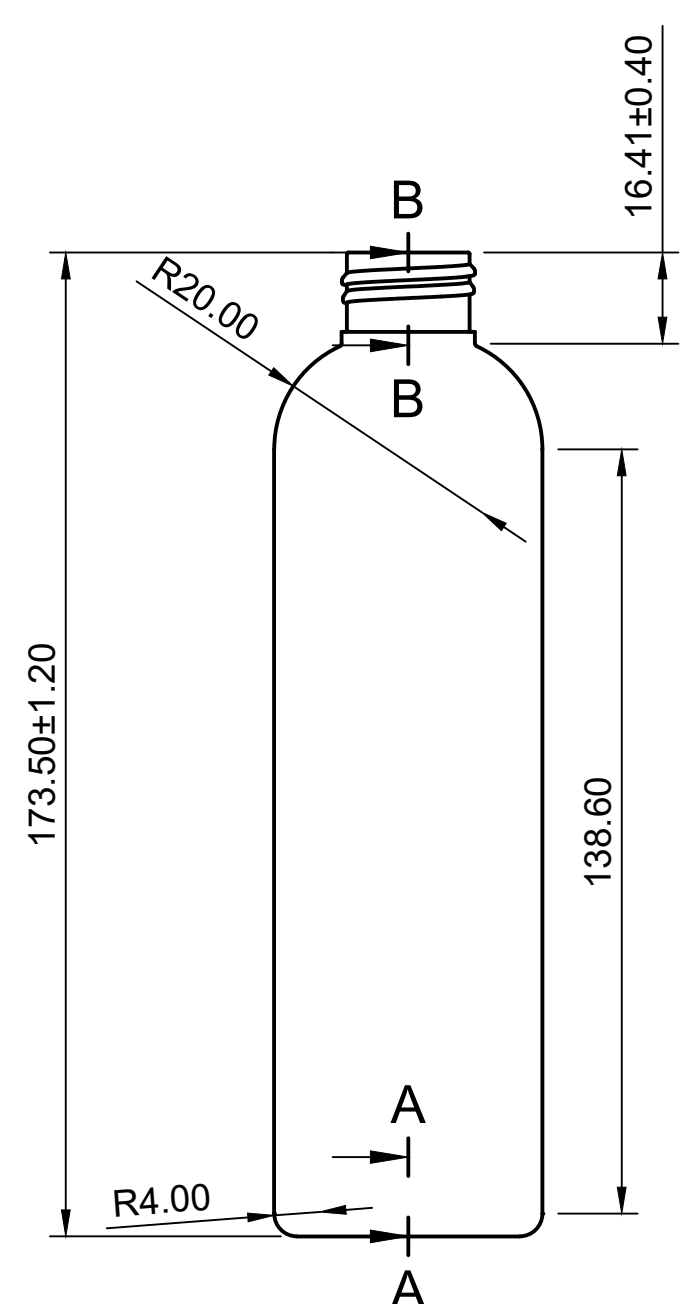

B-B (2:1)

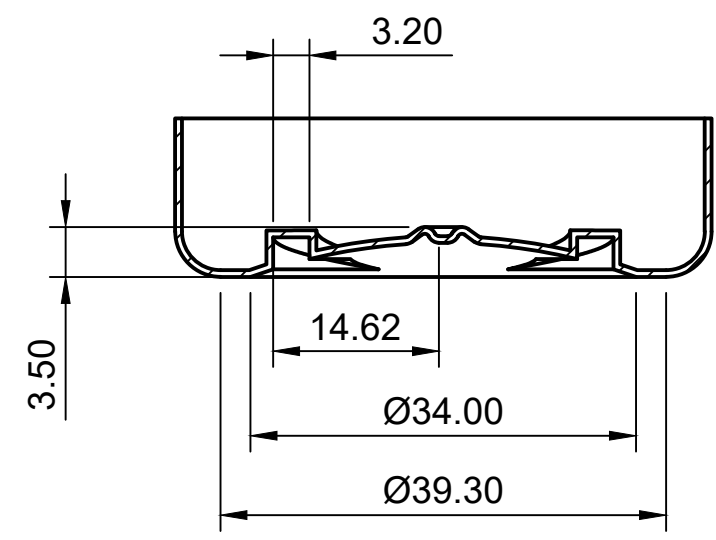

A-A (1.5:1)

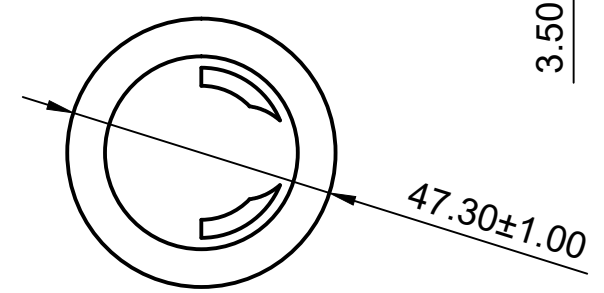

NOTES	
1.- NECK FINISH: 24/410	
2.- PITCH: 8 TPI	
3.- # OF THREADS: 1	
4.- THREAD TURNS: 2	
5.- THREAD ROTATION: Righth Hand	
6.- OVERFLOW CAP. : 254.00+/-4.00 ml	
7.- STD. CAPACITY: 8 fl Oz (236.59 ml)	
8.- WEIGHT : 25.00+/-1.00 gr	
9.- MATERIAL: PET	

Note: Dimensions without specified tolerances have at least +/- 1.5%

PROPRIETARY AND CONFIDENTIAL
 THE INFORMATION CONTAINED IN THIS DRAWING IS THE SOLE PROPERTY OF US PACK GROUP, ANY REPRODUCTION IN PART OR AS A WHOLE WITHOUT PERMISSION IS PROHIBITED

DISCLAIMER: US Pack Group assumes no responsibilities for closure and decorations use in conjunction with this bottle, as well as shelf life and compatibility of product to be filled in this bottle. Dimension Tolerances May increase on pigmented containers

Dept. Design	Scale N/A	Created by A. Flores	7/22/2022	Approved by C. Aguirre	7/30/2022
		Document type dwg	Document status APPROVED		
		Title 8 oz bullet round 24/410 bottle	DWG No. 8 oz bullet round 24/410 bottle Drawing v4*		
		Rev. V4	Date of issue July, 2022	Sheet 1/1	

1 2 3 4 5 6 7 8