



**ORANGE
PRODUCTS,
INC.**

FORM / FM-464

PRODUCT SPECIFICATION SHEET

Issued by: Quality Assurance

Uncontrolled when printed.

Pg. 1 of 2

DATE:	01-FEB-2019	DRAWN BY:	D. BYERLEY	SPECIFICATION #:	PS-021
--------------	--------------------	------------------	-------------------	-------------------------	---------------

ITEM:	1.000" PPH BALL, GRADE 2, FROSTED
MATERIAL:	INEOS H13M-00 or EQUIVALENT
COLOR:	NATURAL
SIZE:	1.000" +/- .002"
SURFACE FINISH:	FROSTED
WEIGHT:	2.20g +/- .2g
WALL THICKNESS:	NOMINAL .050"
STANDARD PACKING:	4,000 / CARTON
OPI PART #:	F10000022012

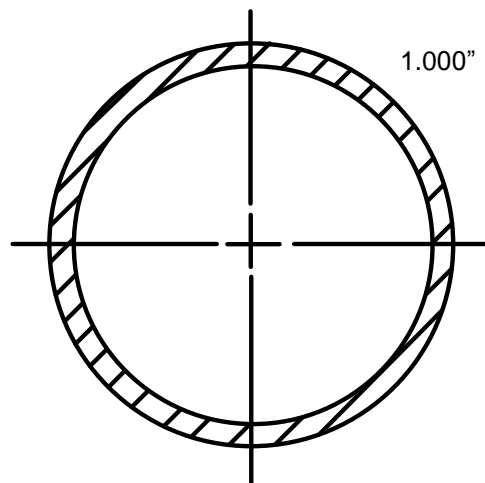

DRAWING NOT TO SCALE

