

2

1

SIDE VIEW

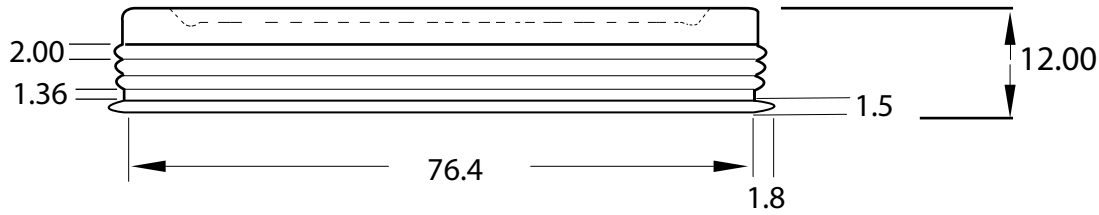

TOP VIEW

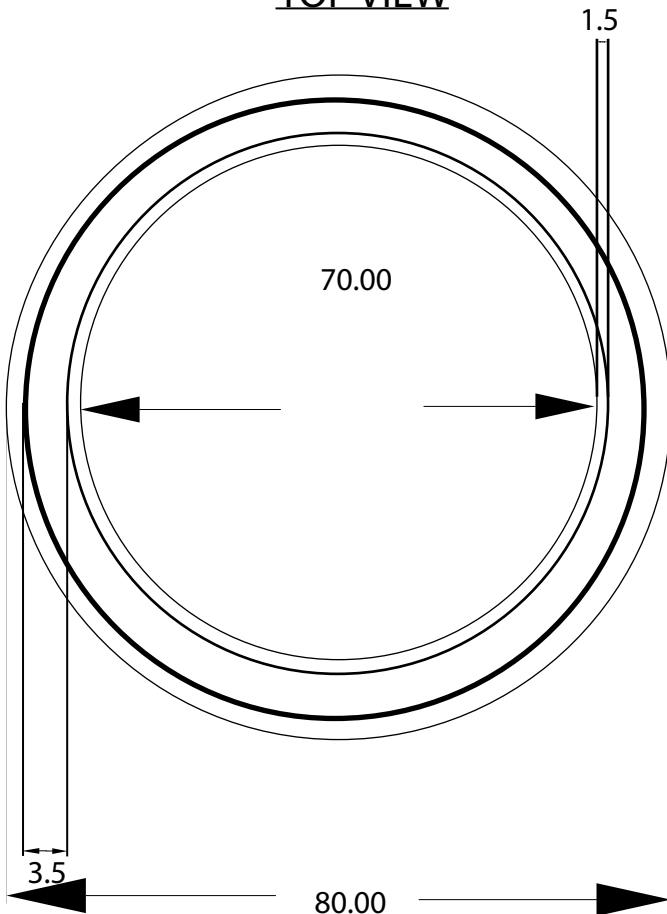

UNLESS OTHERWISE SPECIFIED,
DIMENSIONS ARE IN INCHES

.XX = ±.0-
.XXX = ±.00-
.XXXX = ±.000-
ANGULAR = ±°
FRACTIONAL = ±

SURFACE FINISH

DO NOT SCALE DRAWING

BREAK ALL SHARP EDGES AND
REMOVE BURRS

THIRD ANGLE PROJECTION

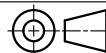

	NAME	DATE
DRAWN	James Blake	02/15/2020
CHECKED		
APPROVED		

TITLE		
Union Street Tin Co. 80.00x12 mm Plain Tinplate Cover Item # 6SC80A		
SIZE	DWG NO.	REV.
A		

MATERIAL	FINISH
Tin	

SCALE	WEIGHT	SHEET
1:1		1 of 2

2

B

B

A

A

2

1

SIDE VIEW

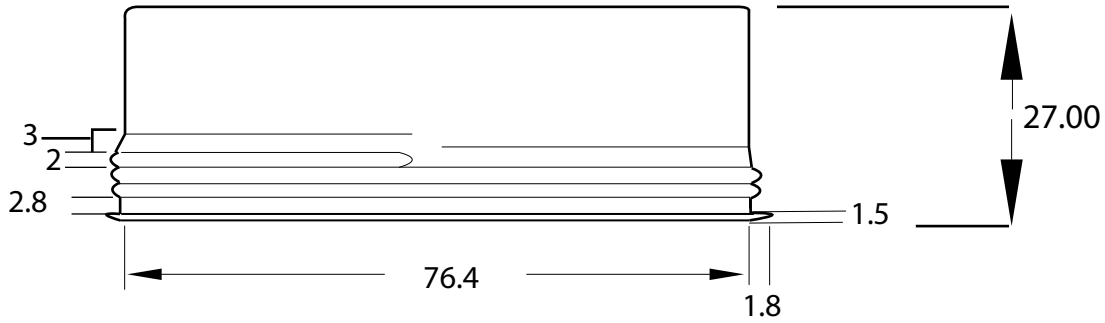

BOTTOM VIEW

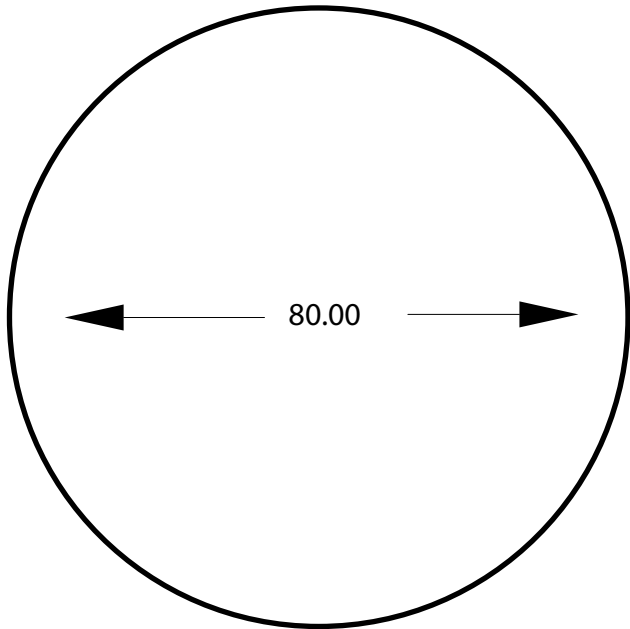

UNLESS OTHERWISE SPECIFIED,
DIMENSIONS ARE IN INCHES

.XX = ±.0-
.XXX = ±.00-
.XXXX = ±.000-
ANGULAR = ±°
FRACTIONAL = ±

SURFACE FINISH

DO NOT SCALE DRAWING

BREAK ALL SHARP EDGES AND
REMOVE BURRS

THIRD ANGLE PROJECTION

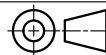

	NAME	DATE
DRAWN	James Blake	02/15/2020
CHECKED		
APPROVED		
MATERIAL	Tin	
FINISH		

TITLE		
Union Street Tin Co. 80.00x27 mm Plain Tinfoil Body Item # 6SC80A		
SIZE	DWG NO.	REV.
A		
SCALE	WEIGHT	SHEET
1:1		2 of 2

2

B

A