

ECN NO.	ZONE	REV.	DESCRIPTION	DATE	ISSUED
		J	UPDATED SALES DRAWING	1/7/14	JPH
		K	UPDATED DIMENSIONAL DATA	7/24/14	PWH

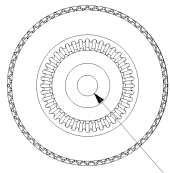

● M (THRU HOLE) ● (TIP)

DIM	MIN	MAX
A	.901	.911
E	.72	.73
H	.525	.535
T	.787	.797

SIZE	DIM	MIN	MAX
.115	M	.105	.125
.085	M	.075	.095

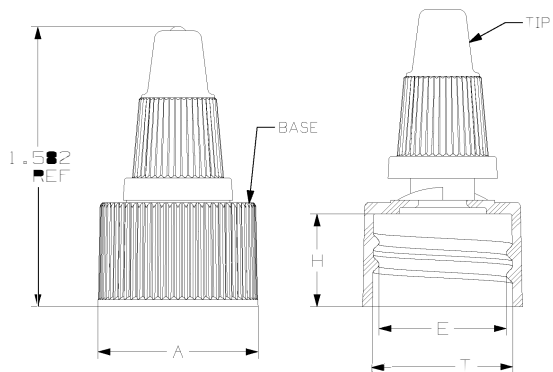

NOTES:

1. MATERIAL: HDPE (BASE) LDPE (TIP)
2. THREAD (MODIFIED BUTTRESS): BASE (1 3/4 TURNS - PITCH 8)
3. TORQUE SPEC. BASE TO BOTTLE: TIGHTENING FORCE 8-12 IN-LBS

THIS DRAWING IS CONFIDENTIAL AND IS THE SOLE PROPERTY OF YORKER PACKAGING AND IS NOT TO BE REPRODUCED OR DISTRIBUTED, IN ANY FORM, WITHOUT PERMISSION.

DIMENSIONS IN INCHES TOLERANCES UNLESS OTHERWISE SPECIFIED:

- 2 PL DEC +/-
- 3 PL DEC +/-
- 4 PL DEC +/-

ANGLES +/-

SURF TEXTURE: ✓

REMOVE BURRS, BREAK SHARP EDGES .015R MAX

DRAWN: G.J.B. DATE: 10/15/01

CHECKED: L.C. DATE: 10/15/01

APPROVED: J.S. DATE: 10/15/01

CUSTOMER:

CUSTOMER PART NO.:

YORKER PART NO.:

YORKER MOLD NO.:



1303 S. Batesville Rd.  
Greer, SC 29650-9301  
Reply to: P.O. Box 2750  
Greenville, SC 29602

**YORKER PACKAGING**  
A Division of Jarden Plastic Solutions

DRAWING TITLE:  
ASSY, 20mm/410 TBC

YORKER DRAWING NO.: 10735-S-K SIZE

SCALE: 2X SHEET: 1 OF 1